

Sirius SI23

Small and Easy to Install Radiation Pyrometers



1-channel pyrometer for non-contact temperature measurement in the short wavelength range, primarily for measurements on bare metals from 50°C.

- Temperature ranges starting at 50°C
- Temperature sub range adjustable in order to increase the accuracy of the analog output
- Full digital signal processing with low uncertainty
- Fast data acquisition with a response time of only 5 ms
- Different optics selectable with small spot sizes from 1.3 mm
- Laser target marking for precise alignment to the measuring object
- Green LED power indicator
- Switchable analog output 0 / 4-20 mA and serial interface RS232 or RS485
- Easy device configuration via interface using the supplied software

Small, Easy to Install, Short-Wave

The pyrometers of series **Sirius** offers an extensive equipment combined with a high-quality internal side, despite its small size. The fully digital signal processing ensures the highest accuracy even at low emissivity levels, the adjustment to different measuring distances allows to find the smallest spot size or the optimum installation location.

For the precise measurement of temperatures on bare metal parts, the shortwave spectral sensitivity of Sirius pyrometers is crucial, because the infrared energy from these surfaces is emitted worse with increasing wavelength. At the same time the influence of emissivity deviation or of an incorrectly adjusted emissivity factor on the measurement accuracy in the short wave infrared is much lower.

Comparison of wavelength ranges of all Sirius models

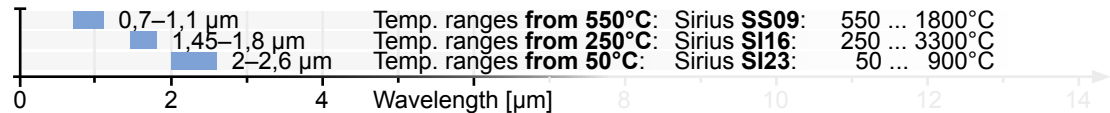

Sighting Method Laser Targeting Light

Sighting is used to pinpoint the location of the measured target.

Laser targeting uses a red laser dot showing the center of the measuring field. At the focus point, the laser dot is the smallest and provides the sharpest image, so that the measuring distance for the smallest spot size can be easily determined.

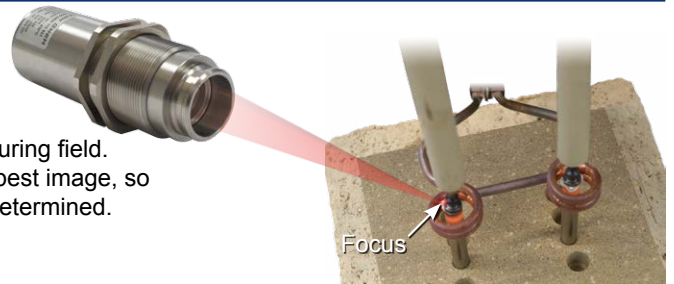

Technical Data

Model	SI23
Temperature ranges	50 – 400°C 100 – 600°C 150 – 900°C
Temp. sub ranges	Any temperature sub-range adjustable within the temperature range (minimum span 50°C)
Spectral range	2–2.6 μm
Detector	InGaAs
Response time t_{90}	5 ms, adjustable up to 10 s
Exposure time	2.5 ms
Uncertainty ($\epsilon = 1$, $t_{90} = 1s$, $T_A = 23^\circ C$)	0.3% of reading in °C + 2°C
Repeatability ($\epsilon = 1$, $t_{90} = 1s$, $T_A = 23^\circ C$)	0.1% of reading in °C + 1 K
Emissivity ϵ	20 – 100%
Analog output	0/4–20 mA, switchable, isolated, max. load: 500 Ω.
Serial interface	Optional RS232 or RS485 (addressable), baud rate 1.2 up to 57.6 kBd, Resolution 0.1°C or 0.1°F
Peak picker	Automatic hold mode or manual time settings to clear (reset)
Parameter settings	Via serial interface and PC software <i>SensorTools</i> or via self-compiled communication program: Emissivity, temperature sub range, settings for peak picker, device address (with RS485), baud rate, response time, selecting analog output 0/4–20 mA, °C/°F.
Power requirement	24 V DC (12–30 V DC), max. 1 VA
Isolation	Voltage supply, analog output and serial interface are galvanically isolated from each other
Sighting	Laser targeting light (red, $\lambda=650$ nm, $P < 1$ mW, class II to IEC 60825-1)
Ambient temperature	0–70°C (The laser targeting light is deactivated at a device temperature from 60°C to prevent its overheating)
Storage temperature	-20–85°C
Relative humidity	No condensing conditions
Housing / protection class	Stainless steel, IP65 to DIN 40 050 with connector
Weight	650 g
CE label	According to EU directives for electromagnetic immunity

Reference Numbers

SI23: Specify with temperature range, serial interface RS23 or RS485 and optics (pre-adjusted measuring distance)

Note: *SensorTools* software is included in scope of delivery, connection cables are not included in scope of delivery and have to be ordered separately.

Features

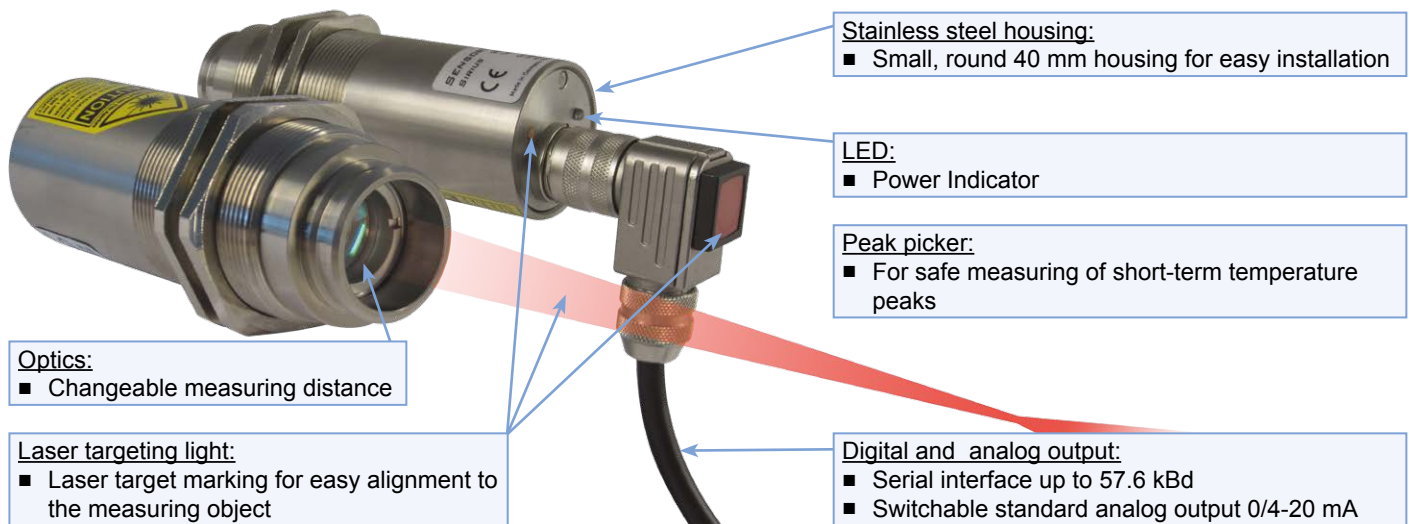

Optics

SI23 are equipped with a fixed optics with changeable lens position to adjust the focus distance onto 8 different distances. The following table provides the optical data at different lens positions.

For reliable measurement the measurement object should be at least as large as the spot size. The values in the tables are exemplary, intermediate values can be interpolated. The pyrometer can be used at distances other than its' focal distance, however the spot size is generally larger and therefore the target size must be larger. The aperture in this case indicates the size of the measuring field next to the optics' lens.

The pyrometer must be properly aligned to the measurement object to detect the temperature correctly. In the focus point of the lens (focal distance) the spot size diameter is smallest. Measurements out of the focus distance are also possible (in front of or behind the focus distance) to determine the average temperature of a bigger spot.

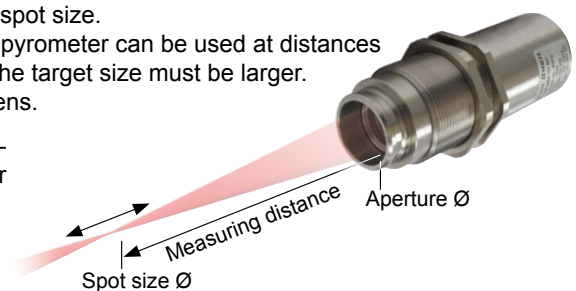

Optics	Measuring distance a [mm]	Spot size M [mm]			Aperture Ø D [mm]
		50 – 400°C	100 – 600°C	150 – 900°C	
OS09-0A	150 mm	2.5 mm	1.7 mm	1.3 mm	18 mm
OS09-0B	165 mm	2.8 mm	1.9 mm	1.4 mm	
OS09-0C	180 mm	3.2 mm	2.1 mm	1.6 mm	
OS09-0D	210 mm	3.8 mm	2.5 mm	1.9 mm	
OS09-0E	250 mm	4.7 mm	3.1 mm	2.4 mm	
OS09-0F	320 mm	6.2 mm	4.1 mm	3.1 mm	
OS09-0G	400 mm	7.9 mm	5.3 mm	3.9 mm	
OS09-0H	650 mm	12.2 mm	8.1 mm	6.1 mm	

Changeable Fixed focus optics

1. Loosen locking ring
2. Set lens position
3. Fix locking ring



Typical Application

Inductive heating has become a fast and efficient method for heating metallic parts in industrial production. Modern induction systems produce quickly and efficiently the high workpiece temperature necessary for soldering.

This temperature is essential to achieve as precise and steady as possible and maintain the required time in order not to change the material structure or even destroy. The optimal solution for this is to find in the fast non-contact temperature measurement with pyrometers and the controlling with special pyrometers optimized PID controllers.

Using a combination of pyrometer and programmable PID temperature controller allows

- to detect temperature changes in the inductive heated component very quickly and
- to set a continuously adjusted output signal to control the high-frequency generator

With a PID program controller **Regulus** you can

- in manual mode, define a setpoint temperature and start to control to that value
- in program mode approach sequentially different setpoint temperatures ramp-controlled or time-controlled
- Automatically detect meaningful initial values for the control parameters P and I for new components and inductors
- Follow, store and analyze later at rest all processes visually via included software
- Make many more adjustments to every possible heating task



Regulus RF

Regulus RD

Sirius SI23

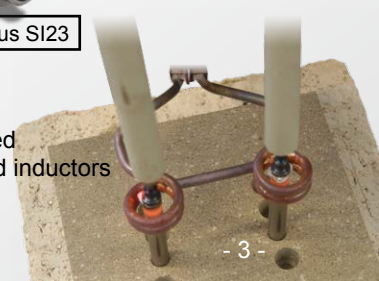

SensorTools Software

The PC software *SensorTools* is our standard software for:

- Measurement display
- Measured value recording
- Processing the results
- Display devices inside temperature
- Changing pyrometer parameters

Program functions:

- Change pyrometer parameters
- Direct measurement data playback
- Adapt recording mode to computer performance
- Export measured values in csv files
- Record interval setting for adapted data size
- External start and stop of recording measured values (via control input on the pyrometer)
- Switch laser targeting light on and off
- Back time recording of measured values after control pulse or extend recording at recording stop
- Create a service file or parameter file with all device and software settings for remote diagnostics

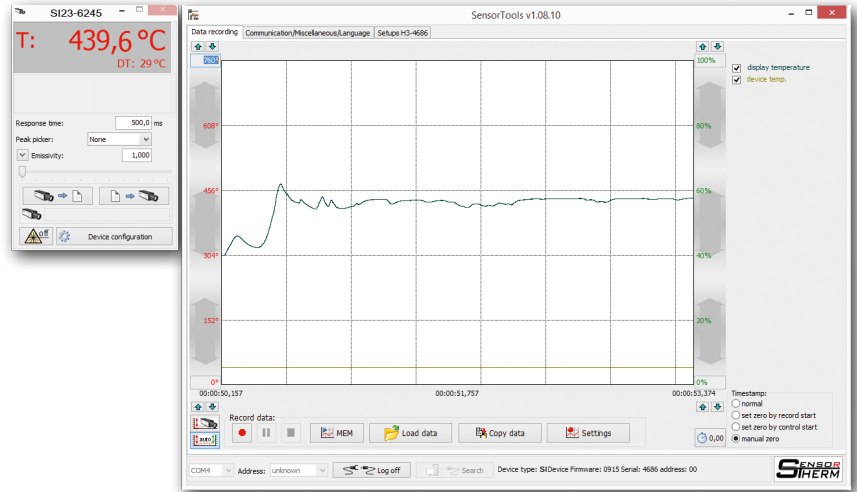

Recommended Accessories

HA11	Adjustable mounting bracket (stainless steel)		
KG60-01	Aluminum water cooling jacket		
HA10	Adjustable mounting bracket for cooling jacket		
HA22	Ball and socket swivel mount for cooling jacket		
BL11	Air purge		
AL11 / AL43	Connection cable, 14-wire (available in 5 m steps) with right angle connector / straight connector		
AL10	Connection cable, 14-wire (available in 5 m steps) with right angle connector and laser targeting light button		
AU11 / AU10 / AU43	Connection cable with interface converter RS232<->USB with right angle connector / laser targeting light button / straight connector		
AV11 / AV10 / AV43	Connection cable with interface converter RS485<->USB with right angle connector / laser targeting light button / straight connector		
IF00-00	LED digital indicator for remote adjustment of IR sensor parameters		
Regulus RD / RF	PID program controller as bench top model / for panel mounting		
NG12 / 20	Power supplies 24 VDC: DIN rail power supply 1.3 A / desktop power supply 2.5 A		

Dimensions

Dimensions in mm

Sirius SI23

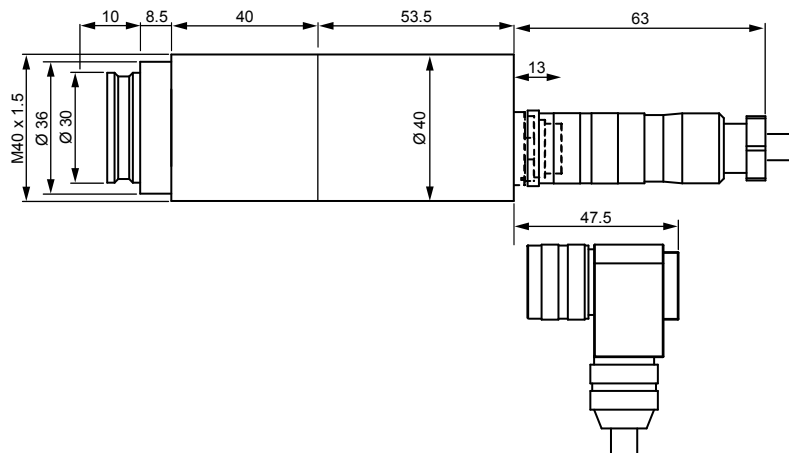

Sensortherm reserves the right to make changes in scope of technical progress or further developments.

Sensortherm-Datasheet_Sirius_SI23 (July 23, 2015)

Sensortherm GmbH

Infrared Temperature Measurement and Control
Hauptstr. 123 • D-65843 Sulzbach/Ts.
Phone.: +49 6196 64065-80 • Fax: -89
www.sensortherm.com • info@sensortherm.com

**SENSOR
THERM**