

Metis MY51

Pyrometer for Glass Measurements

The Pyrometer Series *Metis MY51* with pyroelectrical detector operates in a narrow band around 5.14 μm , where glass above 1 mm thickness is completely opaque. Merchantable uncoated soda lime glasses are also a poor reflector at this waveband, therefore they offer nearly "Black Body" conditions for infrared temperature measurement with *Metis MY51* Series. It is the ideal choice for all kind of applications like forming, bending, tempering, annealing, sealing and hardening of glass in float, construction, automotive and lamp manufacturing processes. For temperature measurement of glass below 100°C we recommend using *Metis MY80* and for temperatures below 50°C *Metis MY81*. Optical and electronic parts are housed in a rugged IP65, extruded aluminum casting to operate in harsh industrial environments.



Chart 1: Metis MY51 Temperature Ranges

Spectral Response	5.14 μm
Temperature Range	80 – 800°C 100 – 1000°C 300 – 1300°C 500 – 2500°C

Each temperature range of MY51 is available as well with different fast exposition times of 10, 40, or 100 ms. Slower models offer better optical resolution (smaller spot size). To achieve effectively the best optical resolution of 200:1, the 100 ms version can be supplied with fixed focus lenses only.

Lenses: The infrared energy radiated by the target is centered via focusable or fixed focus lenses directly on the detector. The focusing feature allows control of the cone of vision and offers the possibility to measure either a small spot (focused) or the average of a bigger spot (out of focus). Fixed focus lenses with larger diameter collect more infrared energy and therefore result in smaller spot sizes. The lenses are made of calcium fluoride CaF_2 which is highly transparent in visible and infrared regions up to 10 μm . If additional windows are necessary they must offer similar optical characteristics.

Chart 2: Focusable Lenses Metis MY51

Lens	Distance	Model MY51 with 5 or 30 ms response time			
		80 – 800°C	100 – 1000°C	300 – 1300°C	500 – 2500°C
OM51-C0	110 mm	1.7 mm	1.2 mm	1.0 mm	0.8 mm
	150 mm	2.6 mm	2.2 mm	1.9 mm	1.2 mm
	200 mm	3.6 mm	3.0 mm	2.5 mm	1.8 mm
OM51-D0	190 mm	2.5 mm	2.1 mm	1.7 mm	1.3 mm
	400 mm	7.0 mm	5.8 mm	4.8 mm	3.6 mm
	680 mm	12.6 mm	10.5 mm	8.5 mm	6.5 mm
OM51-L0	260 mm	3.5 mm	2.9 mm	2.3 mm	1.8 mm
	1500 mm	27.6 mm	23 mm	18 mm	13.7 mm
	4000 mm	64 mm	62 mm	52 mm	37 mm

The detector is sensitive to infrared radiation in an area called **cone of vision**. For the spot size diameter \varnothing at shortest, medium and widest focal distances, please see **Chart 2**. For full scale temperatures up to 1300°C the cone of vision diameter in front of the lens is about 16 mm and about 9 mm for full scale temperatures above. This area has to be kept free from any intervening objects. The spot size diameter for distances not given in the chart can be calculated by interpolation

Chart 3: Fixed-Focus Lenses Metis MY51 with 5 ms, 30 ms und 100 ms response time

Temperature Ranges			80 – 800°C		100 – 1000°C		300 – 1300°C and 500 – 2500°C		
Exposition Times			100 ms	5 + 30 ms	100 ms	5 + 30 ms	100 ms	30 ms	5 ms
Lens	Tube Length *)	Distance	\varnothing	\varnothing	\varnothing	\varnothing	\varnothing	\varnothing	\varnothing
OM51-0E	89 mm	185 mm	2.8 mm	3.9 mm	2.0 mm	2.8 mm	0.9 mm	1.3 mm	1.5 mm
OM51-0F	89 mm	390 mm	3.5 mm	4.9 mm	2.5 mm	3.5 mm	1.2 mm	1.5 mm	1.7 mm
OM51-0G	89 mm	820 mm	5.6 mm	9.5 mm	4.0 mm	6.8 mm	2.5 mm	3.0 mm	3.3 mm
OM51-0H	45 mm	250 mm	3.5 mm	4.8 mm	2.5 mm	3.4 mm	1.4 mm	1.7 mm	2.0 mm
OM51-0K	45 mm	600 mm	8.4 mm	9.8 mm	6.0 mm	7.0 mm	3.0 mm	3.8 mm	4.5 mm

*) see drawing on back page

Spot size and different tube lengths of several fixed focus lenses available with Metis MY51 can be taken from **Chart 3**. The lenses with longer tube of 89 mm offer better optical resolution and therefore smaller spot size. Diameter of cone of vision in front of the lens is **27 mm** for full scale temperatures up to 1300°C and about **15 mm** for full scale temperatures of 2500°C.

Optical Alignment: Metis MY51 Pyrometers are available with 2 different solutions for aiming the sensor onto the target. The first and most popular method is the built-in laser pointer which is also helpful for focusing. The second solution is a sight-through optics version with reticle-defined target which is advantageous for applications where aiming onto hot, incandescent targets is needed. The viewing telescope is equipped with a dimmable sight attenuation filter to protect the eye.

Temperature Output Signals: Metis Pyrometers offer a variety of analog and digital output signals for displaying, recording, archiving and controlling of measured process temperatures. The isolated analog output is selectable from 0 to 4 - 20 mA.

Zero- and full-scale temperatures are adjustable to cover any portion of the instrument's available temperature span to a minimum of 50°C. There is a choice of 2 digital communication interfaces: **RS 232** or **RS 485** max. 19.2 kBd.

Signal Filtering:

For measuring and holding of the highest instantaneous temperature value a **peak picker** (maximum value storage) is installed to compensate interruptions or attenuations in radiation caused by bursts of steam, smoke or dust. It can be reset either automatically or manually by an external contact closure or periodically by user preset clear time. In the last case the highest temperature will be held in a dual storage and will be reset in only one of the two storages after preset clear time to avoid a decrease of the temperature output, should a short cold period appear just at the reset moment.

The **response time** is the length of time it takes for the output signal to reach 90% of a step change in measured temperature. It can be used to filter out rapid variations in temperature and achieve a "more quiet" signal for control or display purposes.

Software:

The **Sensorwin Software** is available for automatic or manual set up of the pyrometer, for recording and for saving of graphical or table files. At the same time these files can be used for quality assurance purposes because the parameter settings are recorded, too. Minimum computer requirements are: 500 MHz clock frequency and Windows 95, 98, ME or XP operating system.

Technical Data

Measurement Uncertainty:	1°C + 0.5% of difference between measured and housing temp. ($T_A = 23^\circ\text{C}$, $\epsilon = 1$, $t_{90} = 1 \text{ s}$)
Repeatability:	0.1% of measured temperature in °C + 0.2°C ($T_A = 23^\circ\text{C}$, $\epsilon = 1$, $t_{90} = 1 \text{ s}$)
Response time t_{90} :	depending on model, 5 ms, 30 ms or 100 ms adjustable up to 10 s
Analog output signal:	0 or 4 – 20 mA selectable, max. load 500 Ω
Emissivity range:	0.20 – 1.00
Temperature resolution:	analog: < 0.1% of adjusted temperature range, digital 0.1°C
Power supply:	24 V AC/DC (12 – 30 V AC/DC), AC: 48 – 62 Hz, max. 2.5 VA
Isolation:	Power supply, analog and digital output are galvanically isolated against each other and against housing
Laser targeting light:	(optional) 650 nm, < 1 mW, class II per IEC 60825-1-3-4
Housing and rating:	Extruded aluminum profile, IP 65 per DIN 40 050
Weight:	700 g
Ambient temperature:	Pyrometer: operation 0 – 70°C, storage -20 – 80°C
Rel. humidity:	No condensing conditions
CE label:	According to EU directives for electromagnetic immunity

Dimensions:

Metis MY51 with Focusable Lens and optional **Swivel Base HA20**

Water Cooling Jacket KG10 for use of Metis MY51 in ambient temp. up to 200°C

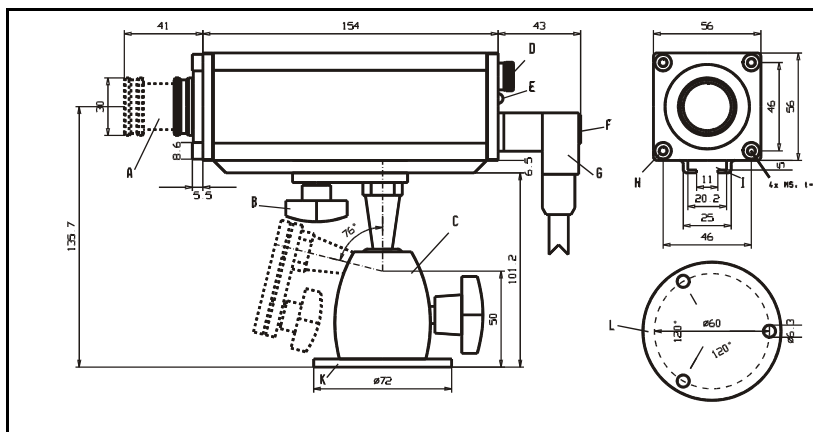

- A: Focusable Lens
- B: Fast-Mount Screw
- C: Swivel Mounting Base
- D: Eye Piece (sight-through optics)
- E: Operation LED
- F: Laser Push Button
- G: 12-pin Connector
- H: Front-Mount Threads
- I: Mounting Rail
- K: Swivel Base Mounting Flange
- L: Base View of item K with Mounting Holes
- M: Mounting Bracket



For additional accessories please contact Sensortherm directly or visit our homepage.

Metis with Fixed Focus Lens and optional **Mounting Bracket HA10**

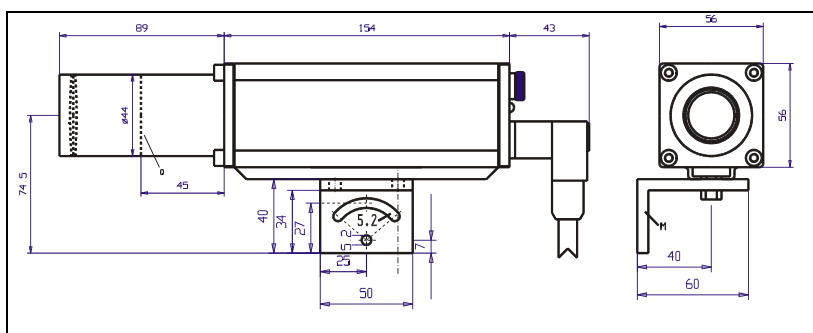

Depending on type, length of lens tube is either 45 mm or 89 mm.

Sensortherm GmbH
 Infrared Temperature Measurement and Control
 Hauptstr. 123, D-65843 Sulzbach/Ts
 Tel.: +49 (0)6196 64065-80
 Fax: +49 (0)6196 64065-89
info@sensortherm.com
www.sensortherm.com