

Metis MP23 / MP25

Temperature measurements on metal surfaces already from 75°C

Pyrometer Series *Metis MP* utilizes lead sulfide detectors with filtered spectral response at relative short infrared wavelengths, and they are therefore often used to measure metal surfaces above 75°C. The emissivity of these surfaces decreases with an increase wavelength, so they offer much better performance than other pyrometers with similar low zero scale temperatures, but with longer wavelength response. Other major advantages are the lower sensitivity for changes in emissivity at shorter wavelengths, the small spot sizes, the fast response time and the digital signal processing which allow the pyrometer to operate within very wide temperature ranges. This makes these units preferable for many other applications, too. Optical and electronic parts are housed in a rugged IP65, extruded aluminum casting to operate in harsh industrial environments.



Chart 1: Temperature Ranges and Spectral Responses

Model	MP23	MP25
Spectral Response	2 – 2.6 μm	2.0 – 2.8 μm
Temperature Range	130 – 700°C	75 – 550°C 100 – 700°C 160 – 1200°C 200 – 1300°C

Lenses:

The infrared energy radiated by the target is centered via focusable lenses directly on the detector. The focusing feature gives you control of the cone of vision and offers the possibility to measure either a small spot (focused) or the average of a bigger spot (out of focus).

The lenses are made of calcium fluoride and protected by sapphire window, materials which are highly transparent in the visible as well as in the infrared spectral regions of *Metis MP* series. If additional windows are necessary, they must offer similar optical characteristics.

Chart 2: Focusable Lenses *Metis MP23* and *MP25*

Lens	Distance	MP25				
		130 – 700°C	75 – 550°C	100 – 700 °C	160 – 1200°C	200 – 1300°C
OM25-A0	100 mm	0.60 mm	0.85 mm	0.60 mm	0.40 mm	0.25 mm
	120 mm	0.85 mm	1.30 mm	0.85 mm	0.50 mm	0.35 mm
	133 mm	1.00 mm	1.60 mm	1.00 mm	0.60 mm	0.40 mm
OM25-B0	190 mm	1.00 mm	1.50 mm	1.00 mm	0.70 mm	0.35 mm
	260 mm	1.60 mm	2.40 mm	1.60 mm	1.10 mm	0.60 mm
	340 mm	2.30 mm	3.40 mm	2.30 mm	1.60 mm	0.80 mm
OM25-C0	350 mm	1.85 mm	2.70 mm	1.85 mm	1.25 mm	0.65 mm
	1200 mm	7.80 mm	11.50 mm	7.80 mm	5.20 mm	2.60 mm
	2600 mm	17.50 mm	26.00 mm	17.50 mm	11.6 mm	5.80 mm

The detector is sensitive to infrared radiation in an area called the **cone of vision**. For the spot size diameter of it at shortest, medium and widest distances, if focused, please see **Chart 2**. For full scale temperatures up to 700°C the cone of vision diameter in front of the lens is about 16 mm and about 9 mm for full scale temperatures above. This area has to be kept free from any intervening objects. The spot size diameter for distances not given in the chart can be calculated by interpolation.

Optical Alignment:

Metis MP Pyrometers are available with 2 different solutions for aiming the sensor onto the target. The first and most popular method is the built-in laser pointer which is also helpful for focusing. The second is a sight-through optics version with reticle-defined target which is advantageous for applications where aiming onto hot, incandescent targets is needed.

Temperature Output Signals:

Metis Pyrometers offer a variety of analog and digital output signals for displaying, recording, archiving and controlling of measured process temperatures. The isolated analog output is switchable from 0 to 4 to 20 mA. Zero- and full-scale temperatures are adjustable to cover any portion of the instrument's available temperature span to a minimum of 50°C.

There is a choice of 2 digital communication interfaces: **RS 232** or **RS 485** max. 57.6 kBd. (Profibus DP optional)

PID Control:

The pyrometer can be equipped with PID control output signal instead of the analog temperature output signal 0 - or 4 - 20 mA. The control features and functions can be operated manually by PC or automatically by digital commands. The auto tune feature automatically determines the P, I and D control parameters. If PID option is chosen, the temperature information will be available from the pyrometer only via digital interface.

Signal Filtering:

For measuring and holding of the highest instantaneous temperature value a **peak picker** (maximum value storage) is installed to compensate interruptions or attenuations in radiation caused by bursts of steam, smoke or dust. It can be reset either automatically or manually by an external contact closure or periodically by user preset clear time. In this last case the highest temperature will be held in a dual storage and will be reset in only one of the two storages after preset clear time to avoid a decrease of the temperature output, should a short cold period appear just at the reset moment.

The **exposition time** is the length of time it takes for the output signal to reach 90% of a step change in measured temperature. It can be used to filter out rapid variations in temperature and achieve a "more quiet" signal for control or display purposes.

Software:

The *SensorWin* software is available for automatic or manual set up of the pyrometer, for recording and for storing of graphical or table files. At the same time these files can be used for quality assurance purposes because the parameter settings are recorded, too. Minimum computer requirements are: 500 MHz clock frequency and Windows 7, XP or Vista operating system.

Technical Data

Measurement uncertainty:	< 400°C: 2°C; > 400°C: 0,3% of measured value in °C + 1 K (T _A = 23°C, ε = 1, t ₉₀ = 1 s)
Repeatability:	0.1% of measured value in °C + 1 K (T _A = 23°C, ε = 1, t ₉₀ = 1 s)
Response time t ₉₀ :	3 ms with dynamic adaptation at low signal levels, adjustable up to 10 s
Emissivity adjustable range:	0.05 - 1.00
Analog output signal:	0 or 4 - 20 mA selectable, 500 Ω max. load
Digital interface:	Either RS232 or RS485 max. 57,6 kBd; optional Profibus DP
Temperature resolution:	analog < 0.1% of adjusted temperature range, digital 0.1°C
Power Supply:	24 V AC/DC (15 - 30 V AC/DC), AC: 48 - 62 Hz, max. 7 VA
Isolation:	power supply, analog and digital output are galvanically isolated against each other and against housing
Laser targeting light:	(optional) 650 nm, < 1 mW, class II per IEC 60825-1-3-4
Weight:	600 g
Housing and protection class:	Aluminum, IP65 per DIN 40 050
Ambient temperature:	operation 0 - 53°C, storage -20 - 60°C
Rel. humidity:	No condensing conditions
CE Label:	according to EU directives for electromagnetic immunity

Dimensions:

Metis MP with Focusable Lens and optional **Swivel Base HA20**

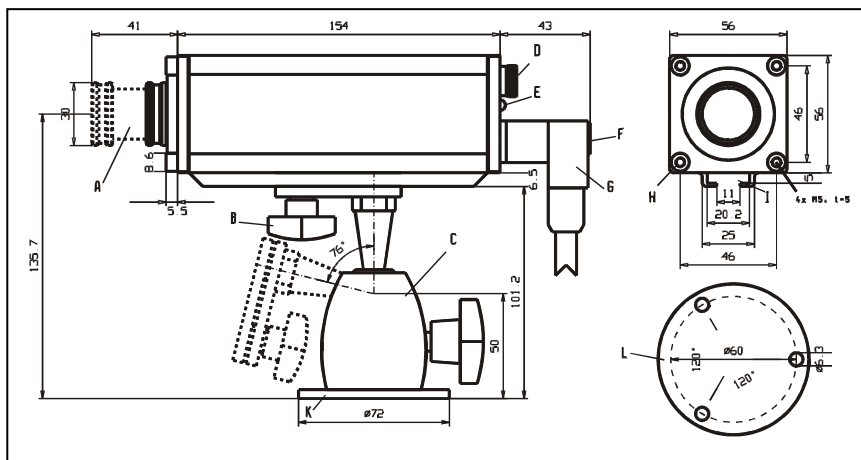

- A: Focusable lens
- B: Fast-Mount screw
- C: Swivel mounting base
- D: Eye piece (for models with view finder only)
- E: Operation LED
- F: Laser push button
- G: 12-pin connector
- H: Front-mount threads
- I: Mounting rail
- K: Swivel base mounting flange
- L: Base view of item K with mounting holes
- M: Mounting bracket

Notice: Standard Accessories for mounting and protecting of *Metis* Pyrometer Series see back page of *Metis*-brochure.

Sensortherm GmbH

Infrared Temperature Measurement and Control
Hauptstr. 123, D-65843 Sulzbach/Ts
Tel.: +49 (0)6196 64065-80
Fax: +49 (0)6196 64065-89
info@sensortherm.com
www.sensortherm.com