

SR30-M2-D1

Digital Class A (secondary standard) pyranometer with heating and tilt sensor

- Heated for best data availability: RVH™ technology outperforms traditional pyranometer ventilation
- The first pyranometer compliant in its standard configuration with the IEC 61724-1:2017 requirements for Class A PV monitoring systems
- Low cost of ownership: remote diagnostics and supported by a worldwide calibration organisation
- Spectrally flat: WMO compliant, also suitable for Plane of Array, diffuse, and albedo measurement



Figure 1 SR30-M2-D1 spectrally flat Class A pyranometer with heating, internal ventilation and tilt sensor

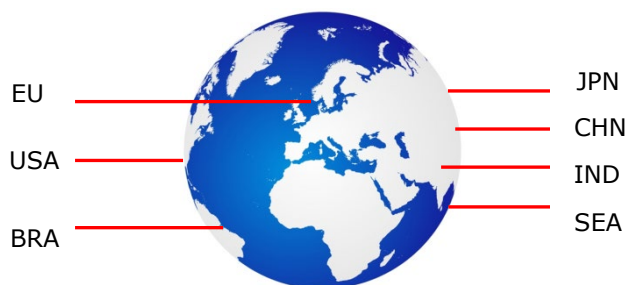

Figure 2 SR30 users are supported by the worldwide Hukseflux calibration and service organisation

Introduction

Welcome to the next level in solar radiation monitoring! The all-digital heated SR30-M2-D1 offers the highest accuracy and highest data availability: using Recirculating Ventilation and Heating (RVH™) technology, SR30 outperforms pyranometers equipped with traditional ventilation systems. SR30 is the ideal instrument for use in PV system performance monitoring and meteorological networks. It measures the solar radiation received by a plane surface, in W/m², from a 180 ° field of view angle. SR30 is an ISO 9060 spectrally flat Class A (previously “secondary standard”) pyranometer. It is employed where the highest measurement accuracy is required. SR30-M2-D1 offers improved electronics over its predecessor SR30-D1.

SR30-M2-D1 offers several advantages over competing pyranometers:

Spectrally flat as required for meteorology and PV monitoring

The new ISO 9060:2018 version defines pyranometer classes A, B and C. The standard also adds a new subclass, called "spectrally flat". The vast majority of users needs to use instruments of the spectrally flat subclass; only spectrally flat instruments measure with high accuracy, also when a cloud obscures the sun, or when the irradiance includes reflected radiation. These situations occur for example when you measure Global Horizontal irradiance (GHI) under partly or fully cloudy skies, when you measure Plane of Array (POA), albedo or net-radiation. Normal instruments, just of class A, B or C, and not spectrally flat, only measure accurately under clear sunny skies. Using "spectrally flat" instruments is essential because this ensures:

- you can measure accurately not only horizontally under clear-blue-sky but also general GHI, POA, albedo and net radiation
- you comply with WMO requirements
- you can use the normal standardised ISO and WMO calibration procedures
- you can also measure separately the diffuse component only (creating a diffusometer) with a shadow ring or shading ball, using the same instrument model
- you can perform uncertainty evaluations with negligible (zero) spectral errors

Heated for high data availability, featuring RVH™ technology

High data availability is attained by heating of the outer dome using ventilation between the inner and outer dome. This space forms a closed circuit together with the instrument body; ventilated air is not in contact with ambient air. RVH™ - Recirculating Ventilation and Heating - technology, developed by Hukseflux, suppresses dew and frost deposition and is as effective as traditional ventilation systems, without the maintenance hassle and large footprint.

- low power consumption: SR30-M2-D1 requires less than 3 W, compared to 10 W for traditional ventilation systems
- low maintenance: SR30-M2-D1 does not require filter cleaning



Figure 3 Heated to counter frost and dew deposition: clear difference between a non-heated pyranometer (back) and SR30 with RVH™ technology (front)

RVH™ uses SR30's built-in heater and ventilator. The dome of SR30 pyranometer is heated by ventilating the area between the inner and outer dome. RVH™ is much more efficient than traditional ventilation, where most of the heat is carried away with the ventilation air. Recirculating ventilation is as effective in suppressing dew and frost deposition at less than 3 W as traditional ventilation is at 10 W. RVH™ technology keeps domes and sensor in perfect thermal equilibrium, which also leads to a reduction of zero offsets.

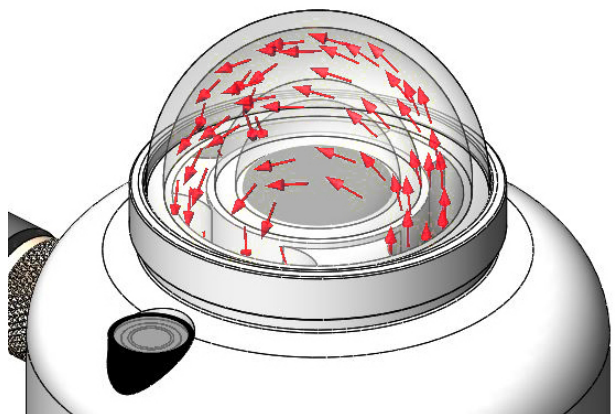

Figure 4 Heating, how it's done: recirculating ventilation and heating between the inner- and outer dome forming a closed circuit with the body is much more power efficient than traditional ventilation systems



Figure 5 SR30-M2-D1 includes a digital tilt angle measurement, very practical for remote checks of instrument orientation. The image shows two SR30's in PV system monitoring, one measuring in Plane of Array (POA).

Tilt angle measurement included

SR30 includes a tilt sensor. This is very practical for remote checks of instrument condition or to monitor PV systems with solar trackers. The sensor measures with high accuracy, within 1° , and is tested and temperature compensated between -30 and $+50^\circ\text{C}$.

Compliant with IEC 61724-1:2017, Class A and B

Only SR30 offers both, without the need for additional accessories. Most competing pyranometers do not even comply with Class B, which requires heating.

Environmental impact

We analysed the environmental impact of SR30 by comparison to its closest competitors; externally ventilated pyranometers such as SR20 + VU01. SR30's impact is significantly lower due to:

- lower power consumption during use
- lower transport volume

Take a look at [our analysis](#).

Low cost of ownership

SR30-M2-D1 is an affordable spectrally flat Class A instrument and is designed for low cost of ownership, which is mainly determined by costs of installation, on-site inspections, servicing and

calibration:

- low demand on infrastructure: SR30's RVH™ requires less than 3 W power, compared to 10 W for traditional ventilation systems
- reduction of unnecessary on-site inspection by remote diagnostics
- designed for efficient servicing; easy local diagnostics.
- supported by an efficient calibration and maintenance organisation. Hukseflux offers local support in the main global economies: USA, EU, China, India, Japan and Brazil. Recalibration is recommended every 2 years, which is good practice in the industry.

Remote sensor diagnostics

Besides solar radiation, SR30 outputs sensor diagnostics, including:

- tilt angle
- internal ventilator speed (RPM)
- internal humidity
- heater current

Remote diagnostics permits real-time status monitoring, reducing the need for (un)scheduled field inspections.

Liabilities covered: test certificates

As required by ISO 9060 for Class A classification, each SR30 is supplied with test results:

- sensitivity
- directional response
- temperature response
- tilt angle measurement

Diffuse radiation measurement

With its outstanding zero offset and spectrally flat specifications, SR30 is also the instrument of choice for high-accuracy diffuse radiation measurement.

Operation in low power mode

Heater and ventilation may be remotely switched on and off; operation at < 0.1 W is possible by switching both the internal ventilator and heater off. Although zero offset will then increase slightly, overall performance will still comply with the Class A classification.

Suggested use

- PV system performance monitoring
- scientific meteorological observations

SR30 design

SR30 pyranometer employs a state-of-the-art thermopile sensor with black coated surface, two domes and an anodised aluminium body. It offers a digital output via Modbus RTU over 2-wire RS-485. The pyranometer dome is heated by ventilating the area between the inner and outer dome using RVH™ - Recirculating Ventilation and Heating - technology.

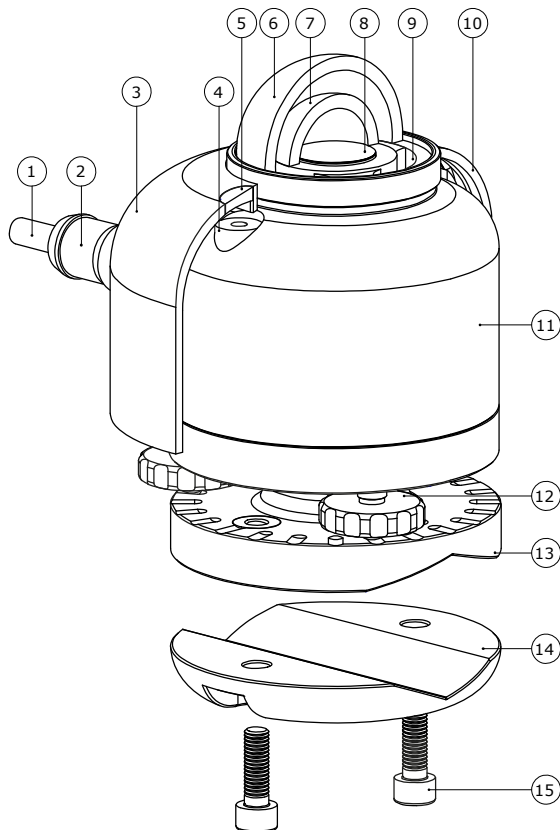

Figure 6 overview of SR30: (1) cable, (2) connector, (3) sun screen, (4) bubble level, (5) bubble level window, (6) outer dome, (7) inner dome, (8) thermal sensor with black coating, (9) internal ventilation vents, (10) quick release system of sun screen, (11) instrument body, (12) levelling feet, (13) optional spring-loaded levelling mount, (14) optional tube mount, (15) screws included with tube mount

Improved electronics

SR30-M2-D1 offers improved electronics design over its predecessor SR30-D1 and is delivered with new Hukseflux Sensor Manager software.

New Hukseflux Sensor Manager software

For communication between a PC and SR30, new Sensor Manager software is included. It (version v2021 or higher) allows the user to plot and export data, and change the SR30-M2-D1 Modbus address and communication settings. Also, the digital outputs may be viewed for sensor diagnostics.

SR30-M2-D1 specifications

Measurand	hemispherical solar radiation
ISO classification	
ISO 9060:2018	spectrally flat Class A pyranometer
ISO 9060:1990	secondary standard pyranometer
WMO performance level	high quality pyranometer
IEC 61724-1 compliance	meets Class A and B PV monitoring system requirements
Calibration uncertainty	< 1.2 % (k = 2)
Measurand	sensor tilt angle
Tilt measurement uncertainty	± 1 ° (0 to 90 ° tilt, -30 to + 50 °C)
Heating	included
Ventilation	included
Technology employed	Recirculating Ventilation and Heating (RVH™)
Standard operating mode	heated and ventilated
Power consumption	< 3 W at 12 VDC
Zero offset a	< 2 W/m ²
Calibration traceability	to WRR
Calibration registers	accessible to users
Calibration certificate	included, content limited according to ISO/IEC 17025- 7.8.1.3.
Spectral range	285 to 3000 x 10 ⁻⁹ m
Rated operating temperature range	-40 to +80 °C
Temperature response	< ± 0.4 % (-30 to +50 °C)
Temperature response test of individual instrument	report included
Directional response test of individual instrument	report included to 95 °
Tilt sensor test of individual instrument	report included (0 to 90 ° tilt, -30 to + 50 °C)
Standard cable length	5 m (see options)
Rated operating voltage range	8 to 30 VDC

Optional operation in low power mode

Operating condition	heater and ventilator [OFF]
Zero offset a	5 W/m ² (unventilated)
Power consumption	< 0.1 W at 12 VDC

Digital communication

Digital output	- irradiance in W/m ² - instrument body temperature in °C - tilt angle in ° - internal humidity in % - ventilator speed in RPM
Communication protocol	Modbus
Transmission mode	RTU
Hardware interface	2-wire (half duplex) RS-485

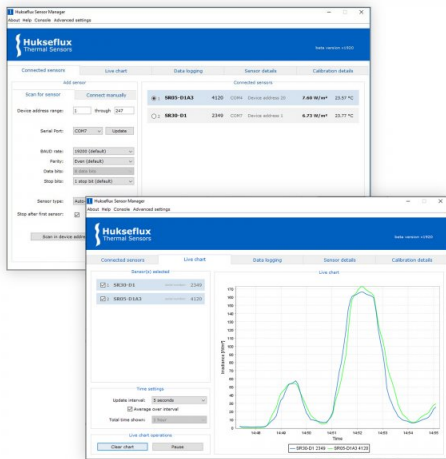

Figure 7 improved Sensor Manager software, included with SR30 pyranometer, allows the user to change the Modbus address and communication settings

Options

- spring-loaded levelling; a practical mount for easy mounting, levelling and instrument exchange on flat surfaces
- tube levelling mount with set of bolts
- longer cable; 10 and 20 metres
- calibration certificate including name and contact information of the customer

Levelling mounts

There are several mounting options available for SR30. They allow for simplified mounting, levelling and instrument exchange on a flat surface or a tube.



Figure 8 optional spring-loaded levelling and tube mount for SR30



Figure 9 PMF01 pyranometer mounting fixture can be used for easy installation of a pyranometer, in this case SR30, in Plane of Array for PV system performance monitoring and meteorological applications

See also

- [SRA30 albedometer](#) consisting of two SR30's
- [SR05](#), an economical solution often used for monitoring small scale PV systems
- [PMF series](#) mounting fixtures
- consult our [pyranometer selection guide](#)
- introduction of SR30 on [our YouTube channel](#)
- [environmental impact analysis of SR30](#)
- [why ventilate and heat pyranometers](#)
- view our complete [range of solar sensors](#)

About Hukseflux

Hukseflux Thermal Sensors makes sensors and measuring systems. Our aim is to let our customers work with the best possible data. Many of our products are used in support of energy transition and efficient use of energy. We also provide services: calibration and material characterisation. Our main area of expertise is measurement of heat transfer and thermal quantities such as solar radiation, heat flux and thermal conductivity. Hukseflux is ISO 9001 certified. Hukseflux products and services are offered worldwide via our office in Delft, the Netherlands and local distributors.

Are you interested in this product?
E-mail us at: info@hukseflux.com

SR30 digital spectrally flat Class A pyranometer with heating

Nowadays, the best pyranometers are made by Hukseflux Thermal Sensors. This overview of features and benefits of SR30-M2-D1 gives you some of the reasons why! Whatever your application is, Hukseflux offers the highest accuracy in every class at the most attractive price level.



Best compliance with standards

- first pyranometer to comply with IEC 61724-1 Class A requirements
- heated domes, Recirculating Ventilation and Heating (RVH™) technology
- tilt measurement

Best paperwork

- all ISO required reports with every individual sensor
 - temperature response testing -30 to 50 °C
 - full directional response testing to 95°
 - tilt sensor testing (0 to 90° tilt, -30 to + 50 °C)



Best accuracy and data availability

- spectrally flat
- suppresses dew and frost deposition
- lowest zero offsets
- no external ventilator required
- low power consumption

Best diagnostics

- tilt angle
- humidity
- temperature
- ventilator speed (RPM)



Best tilt sensor and levelling

- remote check using on-board tilt sensor
- window for visible bubble level
- with optional spring-loaded levelling mount
- easy mounting, levelling and instrument exchange

Best worldwide support

- ISO/IEC 17025 calibration available
 - efficient calibration support
 - fast servicing organisation
 - local stock of spare parts

