

# SR20

## Secondary standard pyranometer

*SR20 is a solar radiation sensor of the highest category in the ISO 9060 classification system: secondary standard. SR20 pyranometer should be used where the highest measurement accuracy is required.*



**Figure 1** SR20 secondary standard pyranometer



**Figure 2** dual setup in PV system performance monitoring

### Introduction

SR20 measures the solar radiation received by a plane surface, in  $W/m^2$ , from a  $180^\circ$  field of view angle. SR20 enables you to attain the highest measurement accuracy and excels in demanding applications. After a thorough programme of acceptance testing, SR20 secondary standard pyranometer was released February 2013.

### Improved measurement accuracy

In order to improve overall measurement accuracy, Hukseflux effectively targeted two major sources of measurement uncertainty: calibration and “zero offset a”.

The initial calibration uncertainty is reduced to less than 1.2 %, an improvement of 15 % relative to competing models. The “zero offset a” specification of SR20 is  $5 W/m^2$  unventilated. Ventilated (with **VU01**) it is just  $2.5 W/m^2$ . Competing models state  $12 W/m^2$  unventilated and  $7 W/m^2$  ventilated.

## Demanding applications

SR20's low temperature dependence makes it an ideal candidate for use under very cold and very hot conditions.

The temperature dependence of every individual instrument is tested and supplied as a second degree polynomial. This information can be used for further reduction of temperature dependence during post-processing.

The incorporated heater reduces measurement errors caused by early-morning dew deposition.

## SR20 design

SR20 pyranometer uses a state of the art thermopile sensor with black coated surface, two domes and an anodised aluminium body. The connector, desiccant holder and sun screen fixation are ultra robust and designed for industrial use. All parts are specified for use across SR20's entire rated operating temperature range.

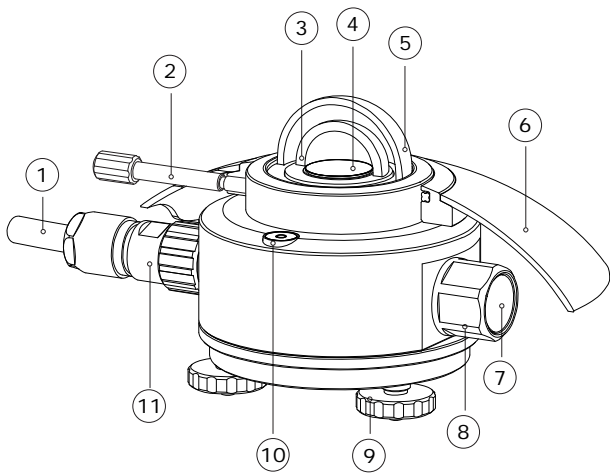

**Figure 3** overview of SR20:

(1) cable, (2) fixation of sun screen, (3) inner dome, (4) thermal sensor with black coating, (5) outer dome, (6) sun screen, (7) humidity indicator, (8) desiccant holder, (9) levelling feet, (10) bubble level, (11) connector

## Uncertainty evaluation

The uncertainty of a measurement under outdoor conditions depends on many factors. Guidelines for uncertainty evaluation according to the "Guide to Expression of Uncertainty in Measurement" (GUM) can be found in our manuals. We provide spreadsheets to assist in the process of uncertainty evaluation of your measurement.



**Figure 4** SR20 with its sun screen removed

## Standards

Applicable instrument classification standards are ISO 9060 and WMO-No. 8. Included in delivery as required by ISO 9060: test certificates for temperature response and directional response. Calibration is according to ISO 9847. PV related standards are ASTM E2848 and IEC 61724.

## Choosing the right instrument

Pyranometers are subject to classification in three classes according to ISO 9060.

From second class to first class and from first class to secondary standard, the achievable accuracy improves by a factor 2.

Measurement accuracy does not only depend on instrument properties, but also on measurement conditions. A very accurate instrument will quickly underperform without a regular schedule of maintenance.

Our pyranometer [selection guide](#) assists you in choosing the right instrument.

Whatever your application is: Hukseflux offers the highest accuracy in every class at the most attractive price level.

### Suggested use

- PV system performance monitoring
- scientific meteorological observations
- reference instrument for comparison
- extreme climates (tropical / polar)



Figure 5 SR20 side view

### See also

- [SR20-D2](#) digital secondary standard pyranometer with Modbus RTU and 4-20 mA output
- [SR25](#) secondary standard pyranometer with sapphire outer dome
- alternative instruments: [SR11](#) and [LP02](#) for lower accuracy measurements
- [SR12](#) first class pyranometer for solar energy testing applications
- the making of SR20 [documented](#)
- view our complete [product range of solar sensors](#)

### SR20 specifications

Measurand	hemispherical solar radiation
ISO classification	secondary standard pyranometer
Calibration uncertainty	< 1.2 % (k = 2)
Zero offset a	5 W/m <sup>2</sup> unventilated
Zero offset a	2.5 W/m <sup>2</sup> ventilated
Calibration traceability	to WRR
Spectral range	285 to 3000 x 10 <sup>-9</sup> m
Sensitivity (nominal)	15 x 10 <sup>-6</sup> V/(W/m <sup>2</sup> )
Rated operating temperature range	-40 to +80 °C
Temperature response	< ± 1 % (-10 to +40 °C) < ± 0.4 % (-30 to +50 °C) with correction in dataprocessing
Temperature response test of individual instrument	report included
Directional response test of individual instrument	report included
Temperature sensor	Pt100 or 10 kΩ thermistor
Heater	1.5 W at 12 VDC
Standard cable length	5 m

### Options

- longer cable, in multiples of 5 metres
- ventilated with [VU01](#) ventilation unit

### About Hukseflux

Hukseflux Thermal Sensors, founded in 1993, aims to advance thermal measurement. We offer a complete range of sensors and systems for measuring heat flux, solar radiation and thermal conductivity. We also provide consultancy and services such as performing measurements and designing instrumentation according to customer requirements. Hukseflux is ISO 9001:2008 certified. Customers are served through the main office in Delft in the Netherlands, and locally owned representations in the USA, Brazil, India, China and Japan.

Interested in this product?  
E-mail us at: [info@hukseflux.com](mailto:info@hukseflux.com)

# SR20 secondary standard pyranometer

Nowadays, the best pyranometers are made by Hukseflux Thermal Sensors. This overview of features and benefits of SR20 gives you some of the reasons why! Whatever your application is, Hukseflux offers the highest accuracy in every class at the most attractive price level.



## Best measurement accuracy

- lowest zero offsets
- lowest calibration uncertainty
- best temperature dependence

- only Hukseflux includes all ISO required reports with every individual sensor
  - temperature response testing from -30 to 50 °C
  - full directional response testing

## Best paperwork

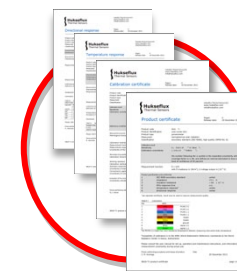

## Best connector

- interchangeable cables
- IP67 grade
- for industrial use

## Best desiccant cartridge

- visible indicator of instrument health
- rugged aluminium design
- serviceable by user



## Best sun screen

- sealed
- corrosion protection of body
- no dry-cooking of bubble level

## Best humidity protection

- wrench-operated
- o-ring compressed to spec
- desiccant service interval > 2 years

