

# SBG01

## Water cooled heat flux sensor

*SBG01 is a water-cooled sensor that measures heat flux. Introduced in 2008, SBG01 has rapidly become the sensor of choice for fire testing. SBG01 is mainly used to test reaction to fire and fire resistance. It is also used as a calibration reference standard for test equipment, for example in flammability and smoke chamber tests. SBG01 complies with the requirements of the most common ASTM and ISO standard test methods.*



**Figure 1** SBG01 water cooled heat flux sensor



**Figure 2** SBG01 is the sensor of choice for fire testing

### Introduction

SBG01 measures heat flux in the range of  $(5 \text{ to } 200) \times 10^3 \text{ W/m}^2$ . Equipped with a black absorber, heat flux sensors of this type are designed for measurement in an environment in which heat flux is dominated by radiation. Using an open detector, SBG01 is also sensitive to convective heat flux. This contribution is usually ignored. Application in environments with lower than  $50 \times 10^3 \text{ W/m}^2$  irradiance levels or environments with significant heat transport by convection is possible but requires a careful evaluation of the measurement uncertainty. SBG01's thermopile sensor generates an output voltage proportional to the incoming irradiance. The sensor is water-cooled. There are 6 models of SBG01; each with a different rated measurement range, calibration reference irradiance level, sensitivity and response time. Water cooling is usually supplied by tap water. There are several optional body designs. The standard body is equipped with a flange. Common options are a smooth cylinder body without a flange (model -C) and threaded body (model -T). Also a thermocouple (type T or K) can be fitted upon request.

### Next level technology

SBG01 has a novel sensor design, which combines the benefits of foil technology of the traditional Gardon gauges with those of the thermopile technology of the traditional Schmidt-Boelter gauges. SBG01 has several advantages:

- robust and serviceable water tubes
- scratch resistant absorber coating (slightly lowered surface)
- safe storage with a practical protection cap

### Suggested use

SBG01 has rapidly become the sensor of choice for fire testing. SBG01 is mainly used to test reaction to fire and fire resistance. It is also used as a calibration reference standard for test equipment for example in flammability and smoke chamber tests.

## Measurement uncertainty

The uncertainty of the measurement with SBG01 should be determined case by case. It is a function of:

1. heat flux sensor properties
2. uncertainty of calibration and quality assurance of the local calibration reference standard
3. verification of the stability of SBG sensors in day to day measurements, before and after use
4. application-related uncertainties, for example caused by the unknown contribution of convection and the representativeness of the measurement location

Hukseflux provides a traceable calibration. The reference standard at Hukseflux is of secondary standard level. It has been calibrated by comparison to the primary standard of the **Statens Provningsanstalt (SP)**, in Sweden. SBG01 sensors as supplied by Hukseflux are calibrated according to ISO 14934-3. Hukseflux is ISO 9001 certified, but not an accredited measurement laboratory according to ISO 17025.

## ISO/ASME standardised practices

Calibration and use of heat flux sensors (officially "heat flux meters") such as SBG01 are subject to standardised practices according to ISO 14934 "Reaction-to-Fire tests - calibration of heat flux meters". The same procedures will be adopted by ASTM. In case the user performs accredited testing or works in an accredited organisation, the user must comply with these standards.

The ISO 14934 standard has 4 parts:

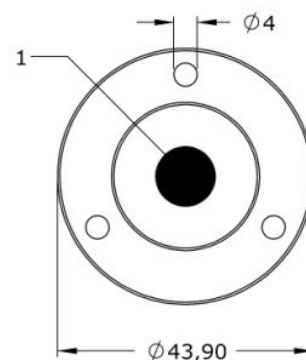
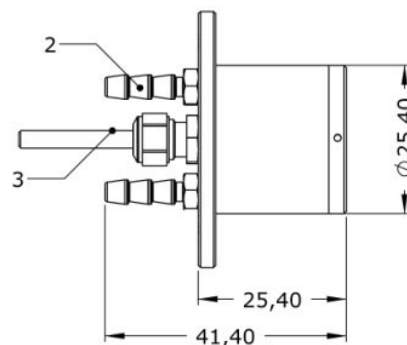
- Part 1: general principle
- Part 2: primary calibration methods
- Part 3: secondary calibration methods
- Part 4: guidance on use of heat flux meters

The most important requirements of these standards are:

- to have 3 local "secondary standard" calibration reference instruments (i.e. sensors calibrated using the primary standard according to ISO 14934-2) for calibration of the "working standards" (i.e. the instruments used for day to day work for calibration of test equipment). This may be done at NIST (USA), SP (Sweden) or LNE (France). Of the 3 calibration reference instruments, 2

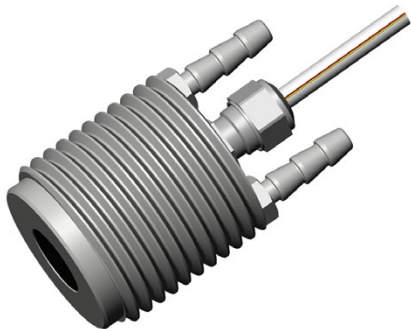
instruments must be kept unused until unexpected results appear or until the first calibration reference standard is sent away for recalibration.

- to calibrate every 2 years one of the reference standards against the primary standard. After calibration this instrument is used to verify the uncertainty of the other 2 calibration reference standards. A single calibration reference sensor is usually calibrated at multiple heat flux levels. It can be used as a reference in the same heat flux range, and by extrapolation also at higher levels.
- to work with working standards only at an irradiance level close to its calibration reference condition.
- to compare working standards to a local calibration reference standard before every test and preferably after every test, following the method specified in ISO 14934-3. The comparison requires a local irradiance source, for example a cone calorimeter.

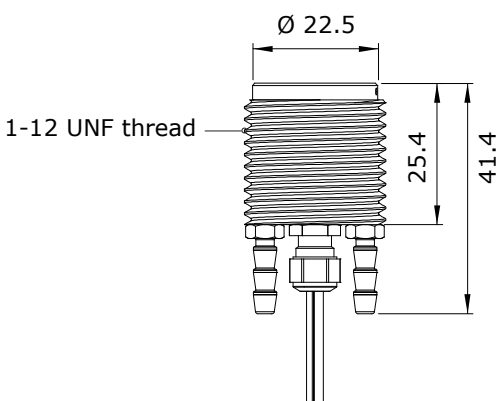
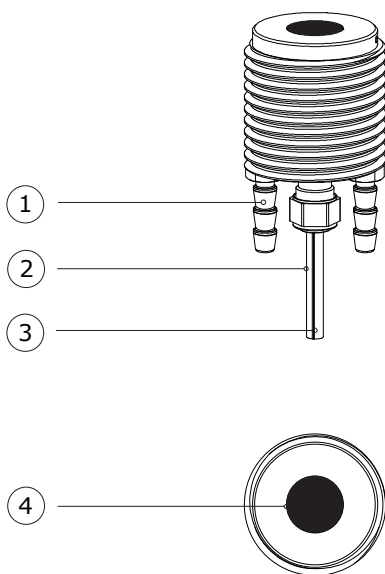


**Figure 3** SBG01 standard model with a smooth body and a flange. Dimensions in  $\times 10^{-3}$  m. Thermopile sensor with black coating (1), water cooling tube (2). Outer diameter tubes:  $4.2 \times 10^{-3}$  m, cable (3). Standard cable length is 2 m. SBG01 is delivered with a practical protection cap for safe storage.

### Optional versions: SBG01-T



**Figure 4** body design: SBG01-T showing its threaded body and optional type T thermocouple (red line)



**Figure 5** optional SBG01-T from top to bottom: 3D view, front view, side view. Dimensions in  $\times 10^{-3}$  m. (1) water cooling tube, outer diameter tubes  $4.2 \times 10^{-3}$  m, (2) cable, (3) thermocouple cable, standard cable length is 2 m, (4) thermopile sensor with black coating

### SBG01 specifications

Measurand	heat flux
Measurand in SI units	irradiance in $W/m^2$
Sensor technology	both Gardon and Schmidt-Boelter
Rated cooling water temperature range	10 to 30 °C
Rated cooling water flow	> 10 l/h (0.003 l/s), preferably 30 l/h (0.01 l/s)
Rated measurement ranges	(5, 10, 20, 50, 100, 200) $\times 10^3 W/m^2$
Response time (63 %) at different rated measurement ranges:	
5, 10 $\times 10^3 W/m^2$	< 450 $\times 10^{-3}$ s
20, 50 $\times 10^3 W/m^2$	< 250 $\times 10^{-3}$ s
100, 200 $\times 10^3 W/m^2$	< 200 $\times 10^{-3}$ s
Limiting measurement range	150 % of rated measurement range
Output signal	DC voltage
Output signal range	> 5 $\times 10^{-3}$ V at rated measurement range
Spectral range	0 to 50 $\times 10^{-6}$ m
Full field of view angle	180 °
Black coating emissivity	> 0.95
Calibration traceability	to ITS-90
Calibration laboratory:	
-management system certification	ISO 9001
-accreditation	not accredited
Calibration method	SBGC secondary calibration method according to ISO 14934-3
Standard cable length	2 m (see options)
Order code standard version	SBG01/rated measurement range/cable length

### Options

- rated measurement range (5, 10, 20, 50, 100, 200)  $\times 10^3 W/m^2$
- longer cable (specify total cable length in m)
- high temperature cable rated temperature range to 400 °C (specify length in m)
- type T or type K thermocouple connected to instrument body (specify -TCT or -TCK), wire exiting next to signal cable. Wire diameter 0.5  $\times 10^{-3}$  m
- smooth cylindrical body without flange (specify - C)
- threaded cylindrical body without flange (specify - T), thread 1-12 UNF

Interested in this product?  
E-mail us at: [info@hukseflux.com](mailto:info@hukseflux.com)