

# NR01

## 4-component net radiometer

*NR01 is a market leading 4-component net radiation sensor, mostly used in scientific-grade energy balance and surface flux studies. It offers 4 separate measurements of global and reflected solar and downwelling and upwelling longwave radiation, using 2 sensors facing up and 2 facing down. NR01 owes its popularity to its excellent price / performance ratio. Advantages include its modular design with 2 pairs of identical sensors, low weight, ease of levelling, and low solar offsets in the longwave measurement. The unique capability to heat the pyrometers reduces measurement errors caused by dew deposition.*



**Figure 1** NR01 4-component net radiometer



**Figure 2** NR01 in use in a typical meteorological station

### Introduction

NR01 measures the 4 separate components of the surface radiation balance: downward and upward solar and longwave radiation. The solar radiation sensors are called pyranometers and the longwave sensors are called pyrgeometers. From these 4 separate components the net radiation is derived. For calculation of sky- and surface temperatures, it is necessary to compensate for irradiated heat by the pyrgeometers themselves (Stefan-Boltzmann law). A Pt100 temperature sensor is included in NR01's body for that purpose. Sunshine duration may be estimated according to the WMO approved pyranometric method.

### The best 4-component net radiometer

Since its introduction in 2007, the **NR01** 4-component net radiometer has become widely applied in networks. Reasons for its popularity:

- lowest price level at top level performance
- heated pyrgeometers, best night-time data availability
- high-accuracy shortwave calibration
- low weight, low mounting costs
- modular design, 2 pairs of identical sensors
- practical levelling, servicing and recalibration

### Operation

Using NR01 net radiometer is easy. It can be connected directly to commonly used data logging systems. The irradiance levels in  $W/m^2$  are calculated by dividing the NR01 outputs, small voltages, by the sensitivities. The longwave irradiance should be corrected using the instrument body temperature. The sensitivities of all sensors are provided with NR01 on its product certificate.

### NR01 design

NR01 net radiometer has a modular design with 2 pairs of identical sensors: it is possible to take the instrument apart and easily replace individual sensors, and recalibrate them in using the same procedure. For this reason it is often selected for use in large monitoring networks.

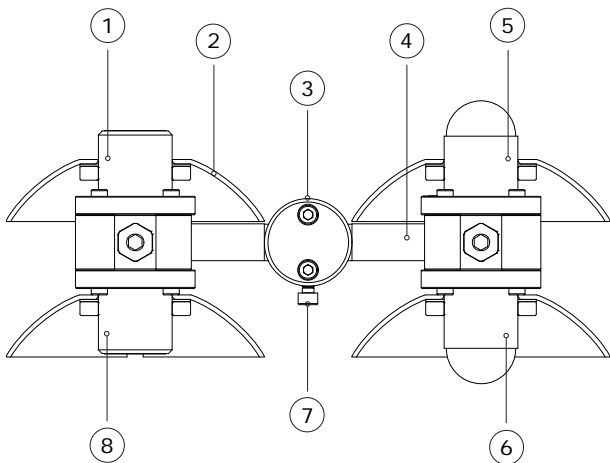

**Figure 3** overview of NR01:  
 (1) upfacing pyrgeometer, (2) sun screens, (3,4,7) levelling assembly for x- and y-axis, (5) upfacing pyranometer, (6) downfacing pyranometer, (8) downfacing pyrgeometer

### Suggested use

- energy balance studies
- surface flux measurements
- climatological networks

### NR01 specifications

Measurand (all 4 radiometer sensors)	net radiation
Measurand	global solar radiation
Measurand	reflected solar radiation
Measurand	downward longwave radiation*
Measurand	upward longwave radiation*
Optional measurand	surface temperature*
Optional measurand	sky temperature*
Optional measurand	albedo or solar reflectance
Optional measurand	sunshine duration
Included sensors	2 x identical ISO 9060 second class pyranometer 2 x identical pyrgeometer with 150 ° field of view angle
Spectral range solar	285 to 3000 $\times 10^{-9}$ m
Spectral range longwave	4.5 to 40 $\times 10^{-6}$ m
Leveling	2-axis levelling assembly included
Heater on pyrgeometer	1.5 W at 12 VDC
Temperature sensor	Pt100
Measurand Pt100	instrument body temperature
Required readout	4 x DC voltage, 1 x Pt100
Mounting	¾ inch NPS tube (not included)
Calibration traceability solar	to WRR
Calibration uncertainty solar	< 1.8 %
Calibration traceability longwave	to WISG
Calibration uncertainty longwave	< 7 %
Rated operating temperature range	-40 to +80 °C
Standard cable length	2 x 5 m (see options)
* Required measurand	instrument body temperature

### Options

- longer cable, in multiples of 5 m, cable lengths above 20 m in multiples of 10 m

### See also

- **RA01** radiometer, a single side version of NR01. Combined with estimates of albedo and surface temperature, this instrument can also be used for estimation of net radiation
- **other sensors for the fluxnet community**
- stand-alone pyranometer: **LP02**
- stand-alone pyrgeometer: **IR02**
- view our complete **range of radiometers**

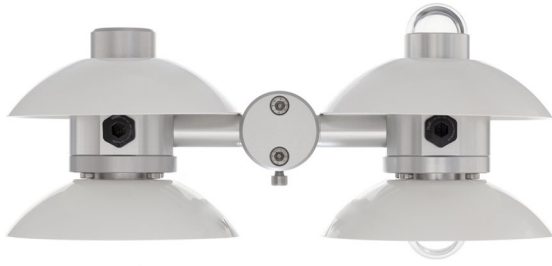

**Figure 4** NR01 4-component net radiometer, including two pyranometers, two pyrgeometers, heater and 2-axis levelling assembly (mounting tube not included)

### NR01 benefits

In order to prevent condensation of water on the pyrgeometer windows the NR01 has internal heating close to the pyrgeometers. This keeps the instrument above dew point. As water blocks longwave radiation, heating will improve the reliability of longwave radiation measurement, in particular at night, when the risk of condensation is highest. Solar offsets in the longwave radiation measurement are very low. NR01 net radiometer is practical to mount; it is much lighter than competing models and a 2-axis levelling assembly is included. Features like these have made NR01 net radiometers popular in energy balance and surface flux studies.

### Standards

Applicable instrument-classification standards are ISO 9060 and WMO-No. 8; Guide to Meteorological Instruments and Methods of Observation.

### Reference users

The National Ecological Observatory Network (NEON) of the USA is the world's largest network employing 4-component net radiometers. After extensive testing, in 2013 NEON released a [list of sensors](#). We are proud that our model NR01 is on it. The Centre for Ecology and Hydrology (CEH) of the UK included NR01 in its new (2014) measurement network. NOTE: the fact that a sensor is used in a network does not constitute a formal endorsement by the network owner.

### About Hukseflux

Hukseflux Thermal Sensors offers measurement solutions for the most challenging applications. We design and supply sensors as well as test & measuring systems, and offer related services such as engineering and consultancy. With our laboratory facilities, we provide testing services including material characterisation and calibration. Our main area of expertise is measurement of heat transfer and thermal quantities such as solar radiation, heat flux and thermal conductivity. Hukseflux is ISO 9001:2008 certified. Hukseflux sensors, systems and services are offered worldwide via our office in Delft, the Netherlands and local distributors.

Interested in this product?  
E-mail us at: [info@hukseflux.com](mailto:info@hukseflux.com)